



**PAMIBIA UNIVERSITY**  
OF SCIENCE AND TECHNOLOGY

**FACULTY OF NATURAL RESOURCES AND SPATIAL SCIENCES**

**DEPARTMENT OF LAND AND PROPERTY SCIENCES**

<b>QUALIFICATION(S):</b> BACHELOR OF PROPERTY STUDIES DIPLOMA IN PROPERTY STUDIES	
<b>QUALIFICATION(S) CODE:</b> 08BPRS 06DPRS	<b>NQF LEVEL:</b> 5
<b>COURSE CODE:</b> BCS520S	<b>COURSE NAME:</b> BUILDING CONSTRUCTION AND SERVICES
<b>EXAMS SESSION:</b> JANUARY 2020	<b>PAPER:</b> THEORY
<b>DURATION:</b> 3 HOURS	<b>MARKS:</b> 100

<b>SECOND OPPORTUNITY/ SUPPLEMENTARY EXAMINATION QUESTION PAPER</b>	
<b>EXAMINER(S)</b>	ELINA TEODOL
<b>MODERATOR:</b>	VERINJAERAKO KANGOTUE

<p style="text-align: center;"><b>INSTRUCTIONS</b></p> <ol style="list-style-type: none"><li>1. Read the entire question paper before answering the Questions.</li><li>2. Please write clearly and legibly!</li><li>3. The question paper contains a total of <b>five (5) questions</b>.</li><li>4. You must answer <b><u>ALL QUESTIONS</u></b>.</li><li>5. Make sure your Student Number is on the EXAMINATION BOOK(S).</li></ol>
--

**PERMISSIBLE MATERIALS**

1. Non-programmable Scientific Calculator

**THIS QUESTION PAPER CONSISTS OF 8 PAGES** (Including this front page)

---

Question 1

For each of the following statements indicate whether it is 'TRUE' OR 'FALSE'. Each correct answer carries 1 mark. (20)

- a) Purlin is the roof member which is placed horizontally to support common rafter of a sloping roof.
- b) The traditional set-up of the building team in the construction industry includes the employer and architect only.
- c) Any foundation may fail as a result of subsidence due to mining underground and increase in the water table only.
- d) The device for providing flushing of water and receiving of excrement is known as Water Closet (WC).
- e) The performance requirements of any building include among others its appearance, sound control, dimensional suitability, weather exclusion and fire protection.
- f) System building (Closed system Building) refers to a method of erecting a building based on the form of construction in which the component parts of the building fabric are partly factory produced.
- g) Mastic Asphalt hardens and shrinks in direct sunlight and this causes "crazing".
- h) In building construction working on sloping sites refers to 'reducing floor analyses'.
- i) Building components will develop damages whenever the stress in the component exceeds its strength.
- j) Party wall refers to a wall separating two detached properties that are in separate ownership such as in terraced houses.

- k) Staircase is usually a recommended means of escape in a multi-storey building.
- l) A Side Hinged Folding door provide easy 100% opening of doorway.
- m) Building finishes can be categorised into groups of wall finishes, joinery and ironmongery only.
- n) Pitched roof is the type of roof suitable in climatic location (zones) where rainfall is insufficient, and temperature is high.
- o) In floor construction, floor systems must transfer their loads horizontally across space to either beams or columns or to bearing walls.
- p) Mechanical transportation in buildings includes lifts and escalators only.
- q) Tyrolean render is a wet dash that is thrown on the wall. It is usually of cement and coarse sand with no colouring agent.
- r) The vertical member fixed between steps and handrails are known as Balusters.
- s) In brick masonry, bricks laid with the shorter faces as seen in the elevation is generally known as Stretcher bonding.
- t) A roof which slopes in four directions is called Hip roof.

[20]

---

**Question 2**

a) Study the two types of drawings below and complete the table provided by matching the numbered orthogonal drawings with the corresponding isometric view. (10)

Orthogonal drawings	1		2		3		4		5																				
	6		7		8		9		10																				
Isometric Drawings	A		B		C		D		E		F																		
	G		H		I		J		K		L																		
	<table border="1" style="margin-left: auto; margin-right: auto;"> <tr> <td>1</td><td>2</td><td>3</td><td>4</td><td>5</td><td>6</td><td>7</td><td>8</td><td>9</td><td>10</td> </tr> <tr> <td> </td><td> </td><td> </td><td> </td><td> </td><td> </td><td> </td><td> </td><td> </td><td> </td> </tr> </table>										1	2	3	4	5	6	7	8	9	10									
1	2	3	4	5	6	7	8	9	10																				

b) Label the twelve (12) individual components of the roof construction below. (6)

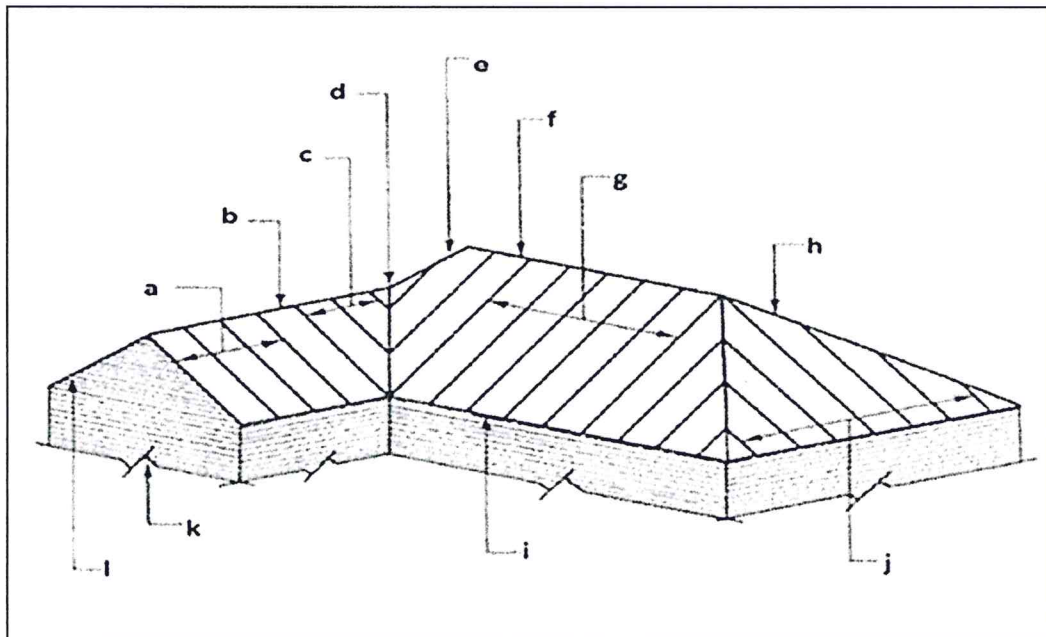



- c) Differentiate between the following as used in building construction: -
- i) The traditional method of building and conventional method of construction. (3)
  - ii) An Employer and an Architect in a major construction work. (2)
  - iii) A Resident Engineer and a Clerk of works. (3)
  - iv) A Superstructure and a Substructure. (3)
  - v) Unburnt bricks and burnt bricks (3)

[30]

---

**Question 3**

- a) Highlight the difference between a panel door and a flush door. (3)
- b) Explain in brief the term 'Slenderness Ratio' in structural strength and stability of a building. (2)
- c) Distinguish between the following terms as used in building construction: -
- i) Facing and Engineering bricks (2)
  - ii) Damp proof Course and Damp proof membrane (2)
  - iii) Arches and Lintels (indicate how loads are transmitted) (2)
  - iv) Cross and Party walls (2)
- d) Highlight and give a brief explanation of the four (4) methods involved in construction which enable a building to resist the imposed loads by either Compression or Tension or combination of the two. (4)
- e) Identify the following types of Pitch roofs. (3)

i)

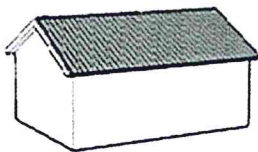

ii)

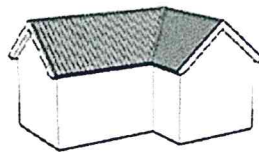

iii)

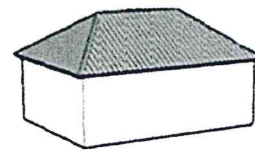

f) Highlight five (5) advantages of deep strip foundation over the traditional strip foundation. (5)

g) Identify each of the following basic types of Windows on the basis of the ways it is opened. (4)

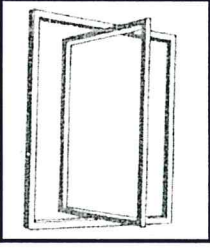
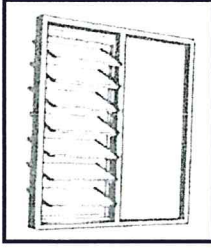
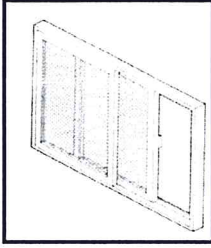
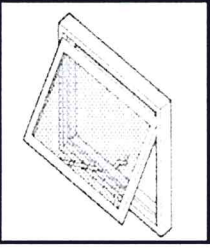
i)	ii)	iii)	iv)
 <p>(1)</p>	 <p>(1)</p>	 <p>(1)</p>	 <p>(1)</p>

[29]

**Question 4**

- a) Mention the five (5) factors affecting the choice of materials for a roof structure. (2.5)
- b) State the three (3) main process of plastering in building construction. (1.5)
- c) Identify the following type of building components: (8)

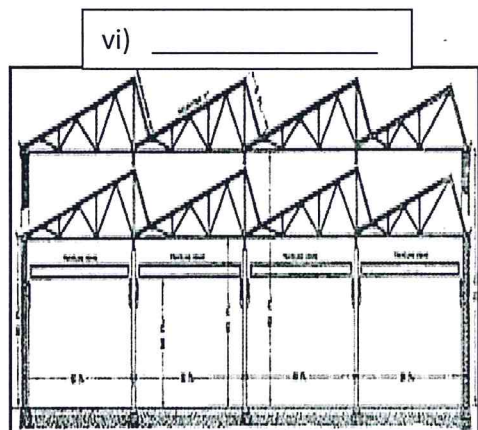
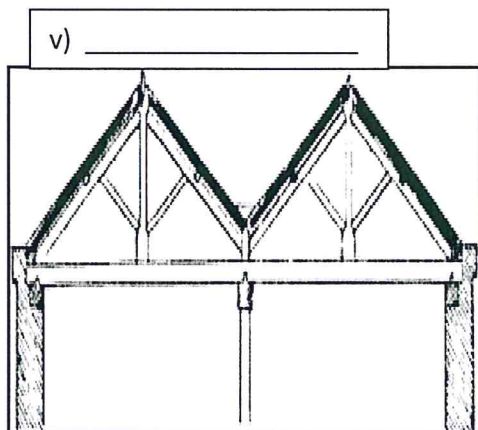
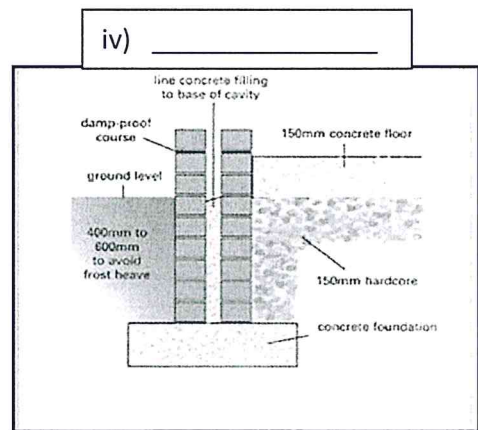
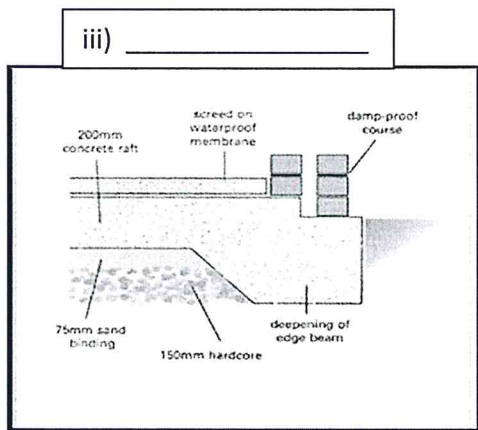
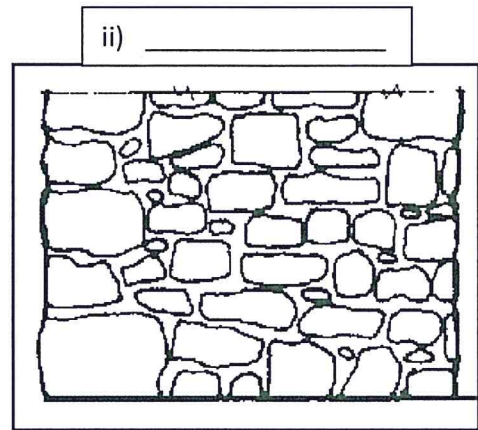
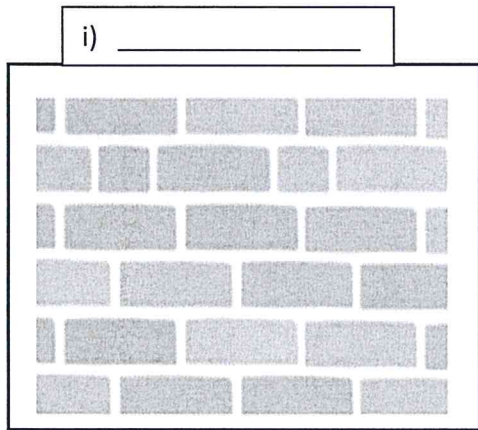

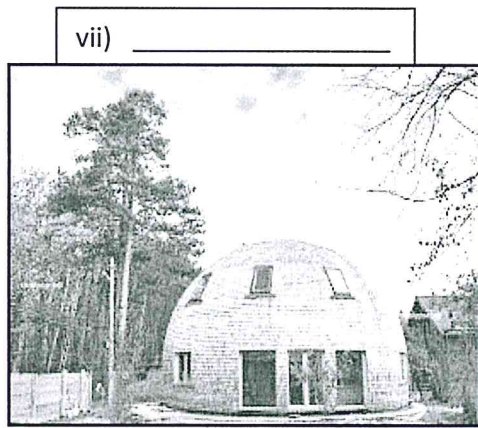

(1)

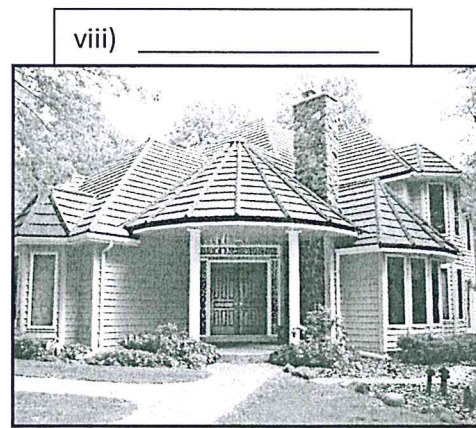

(1)

d) Outline any four (4) most common paints for building available in the market. (2)

e) Identify the following types of pitch roof on the basis of roof span and position of tie. (4)

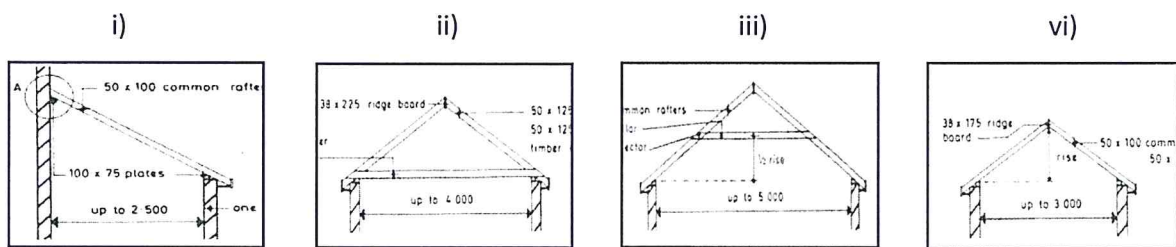

f) Identify each of the following cut bricks. (3)

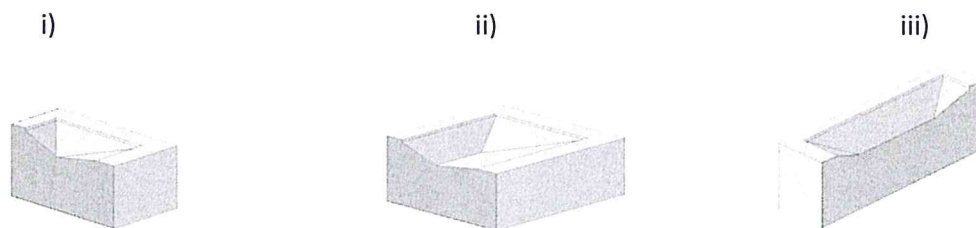

[21]

All the best of luck.